

Technical innovation benefits the world



# RNB 2000

## Series Variable Frequency Drive

Product brochure | English version

**RENLE**

## RNB2000 Series Variable Frequency Drive

# Show Extraordinary in Various Fields

RNB2000 series vector variable frequency drive (VFD) is known for its powerful multi-functions and stable high performance. The series VFD can drive three-phase AC asynchronous motor/ three-phase AC permanent magnet synchronous motor. It has good dynamic performance and superior overload capacity in the control and adjustment of three-phase asynchronous motor / three-phase synchronous motor torque and speed, including the output with low speed and high torque. Supporting a variety of I/O expansion boards, PG boards, and communication expansion boards, it is widely used in various automated production equipment and automated production lines.



Fan

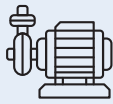

Water Pump

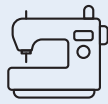

Textile

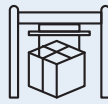

Packaging



Paper-making



Hoisting

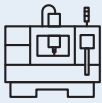

Machine Tools



Petroleum



Mining



Metallurgy

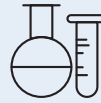

Chemical Industry



## Model Description

R N B 2 X X X — 2 S

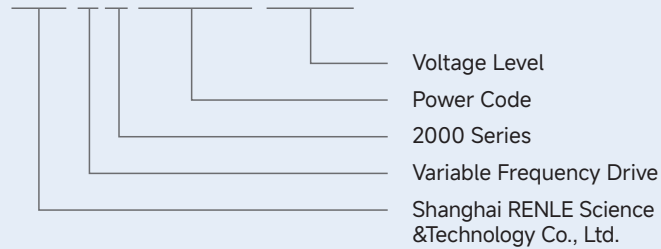

<b>RN</b>	Shanghai RENLE Science & Technology Co., Ltd.
<b>B</b>	Low-voltage Variable Frequency Drive
<b>2</b>	2000 Series
<b>XXX</b>	Power Code: such as 000: 0.75kW; 001: 1.5kW; 037: 37kW; 110: 110kW...
<b>2S</b>	--: 380 VAC 2S: 220 VAC Q: Specialized for Hoisting U: Specialized for Oilfield HF: Specialized for High-speed Permanent Magnet Synchronous Motor

## Product Feature

RNB2000 series VFD, with its high-end control platform, rich interface resources, multiple communication modes, perfect control algorithms and flexible expansion interfaces, can meet the high standard requirements of production processes in many applications.

- Adopting the latest motor control special digital signal processor (DSP) of TI, USA, its main frequency can reach 150 MHz.

- Adopting the fourth-generation IGBT module of Infineon, Germany, combined with 175°C maximum junction temperature characteristic and PWM modulation mode, it can reduce switching losses and eliminate the need to derate the driver even at 50°C ambient temperature.

- Supporting asynchronous and permanent magnet synchronous motors, it can recognize the motor parameters accurately. Two sets of motor parameters can be set, allowing the drive to switch between two different motors by the communication or multi-function terminal.

- V/F control mode enables high-precision current limit control so that there will be no overcurrent alarm for fast acceleration/deceleration or stall and the drive can be protected. Vector control mode enables high-precision torque limiting control, so that the drive can output strong torque or soft torque according to the user's process control requirements and the mechanical equipment can be protected.



Control Mode	Start Torque	Speed Range	Speed Precision	Torque Response
V/F control	0.5Hz 180%	1: 100	±0.5%	
Vector control without PG	0.5Hz 180%	1: 100	±0.2%	<10ms
Vector control with PG	0 Hz 200%	1: 200	±0.02%	<5ms

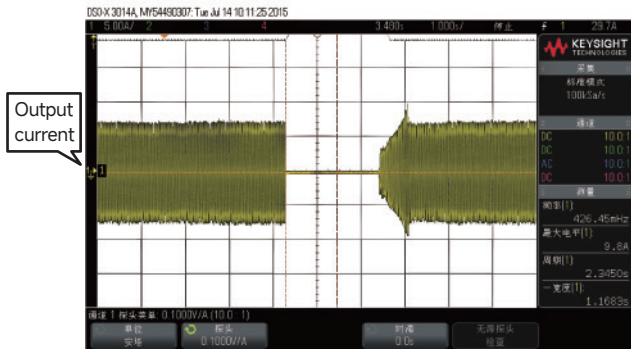

Speed search start

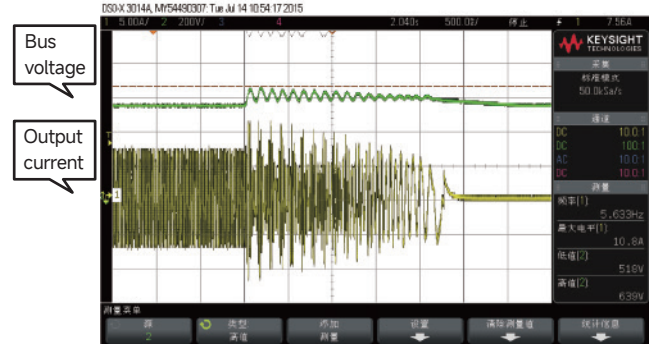

Overvoltage suppression

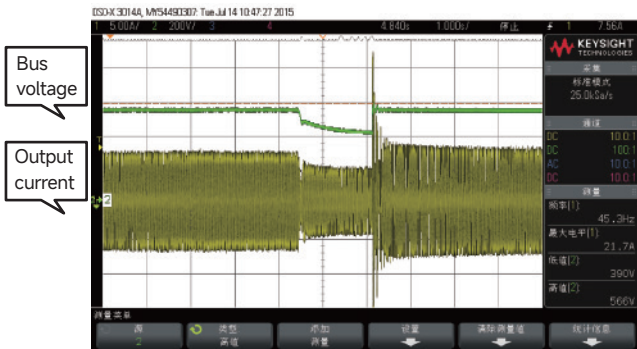

Undervoltage adjustment

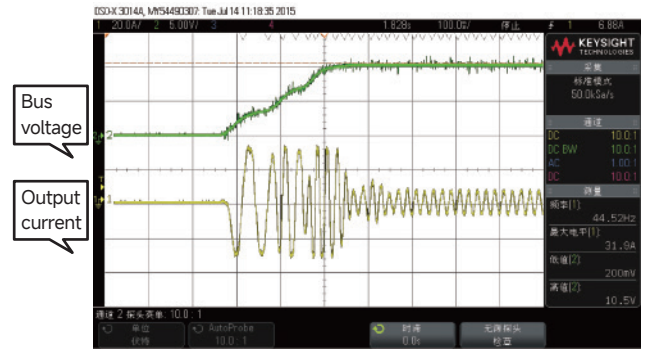

Overcurrent stall protect function

- Under the V/F separation control mode, the output frequency and output voltage can be set separately. This control mode applies to frequency conversion power supply and torque motor control, etc.
- Intelligent expansion interface, allowing simultaneous access to two expansion cards, to meet the user requirements for industry-specific control.
- When the encoder is positioned not at the shaft end, PG vector control can still be realized if the shaft and the motor shaft keep a fixed deceleration ratio.
- Speed search is accurate and reliable, and supports a no-impact smooth start of rotating motor.
- Process PID control owns abundant settings and feedback modes, supporting the free switch between two groups of proportion, integration, and differential parameters as well as the choice between positive and negative feedback features. This control applies especially to save energy for fans and pumps.
- DC power input is supported, enabling users to form a common DC bus application conveniently.
- Overvoltage stall protection:

During the fast deceleration of a large inertia load, the regeneration energy may result in an overvoltage fault. The instantaneous adjustment of output frequency can reduce the probability of overvoltage tripping, so the continuous and reliable operation of the system is

ensured.

- Undervoltage adjustment:

When instantaneous Undervoltage or power failure occurs, the DC bus voltage remains constant through the automatic reduction of output frequency, so the continuous operation of the driver within a short time is guaranteed. This function applies to fans and pumps.

- Overcurrent stall protection function:

During fast acceleration of the heavy load, the instantaneous large slip may result in an overcurrent fault. The instantaneous adjustment of output frequency can reduce the probability of overcurrent tripping, so the continuous and reliable operation of the system is ensured.

- Low-frequency oscillation suppression function:

During the no-load or light load start of a large power motor, acute oscillation may occur and result in fault tripping. Enabling this function can suppress oscillation effectively and ensure reliable operation of the system.

- Wave-by-wave current limiting function:

During heavy load start or abrupt increase of heavy load, this function enables automatic limitation of the output current before the overcurrent fault occurs, and avoids frequent tripping of the VFD.

- Parameter backup is available. It provides convenience to the user for parameter backup, testing and restoration.



## Product Specification

### ▼ RNB2000 Series VFD Technical Parameter Sheet

<b>Input-output characteristics</b>	Input voltage range	Single-phase 220 VAC (-15%) ~ 240 VAC (+10%); Three-phase 380 VAC (-15%)~ 440 VAC (+10%)
	Input frequency range	50 ~ 60Hz±5%
	Output voltage range	0 ~ Rated input voltage
	Output frequency range	0 ~ 600Hz, unit 0.01Hz
	Output overload capacity	150% 1 min; 180% 10s; 200% 1 s
<b>Operation control characteristics</b>	Control mode	V/F control; No PG vector control 0 (for synchronous motors); No PG vector control 1 (for asynchronous motors)
	Speed control range	Asynchronous motor 1: 200 (V/F control, No PG vector control 1); Synchronous motor1: 20 (No PG vector control 0)
	Speed control accuracy	±0.5% (V/F control); ±0.2% (No PG vector control)
	Speed fluctuation	± 0.3% (No PG vector control)
	Torque response	<20ms (No PG vector control)
	Torque control accuracy	10% (No PG vector control)
Starting torque	Asynchronous motor: 0.25Hz/150% (No PG vector control 1); Synchronous motor: 2.5 Hz/150% (No PG vector control 0)	

> continued from previous table

<b>Basic functions</b>	Starting frequency	0.00 ~ 50.00Hz	
	Acceleration and deceleration time	0.0 ~ 3000.0s	
	Carrier frequency	1.0kHz ~ 15.0kHz	
	Frequency setting mode	UP/DOWN setting, digital setting, analog setting, pulse frequency setting, multispeed operation setting, simple PLC setting, PID setting, Modbus communication setting, PROFIBUS communication setting, etc. A combination of settings and switching of setting channels is possible.	
	Start-up method	Starting frequency start, Start after DC brake, speed search start	
	Stopping method	Deceleration stop, free stop, deceleration stop + DC brake, deceleration stop + flux brake	
	Motor type	asynchronous motors, permanent magnet synchronous motor	
	DC braking capacity	DC braking frequency: 0 ~600Hz; DC braking waiting time: 0 ~ 50s; DC braking current: 0.0 ~ 100.0% (VFD rated current); DC braking time: 0.0 ~ 50.0s.	
	Automatic voltage adjustment	It can keep a constant voltage output when the power grid voltage changes	
	Instantaneous frequency reduction	It can reduce the frequency instantly to maintain the bus voltage when the power grid is undervoltage.	
<b>Control terminals</b>	Digital input terminals	10 inputs as standard, 1 of which can be used as a high-speed pulse input (HDI1)	
	Analog input terminals	3 analog inputs as standard : AI1: 0 ~ 10V or 0/4 ~ 20mA input selectable AI2: 0 ~10V or 0/4 ~ 20mA input selectable AI3: -10V ~ +10V input	
	Digital output terminals	2 multi-function collector outputs as standard, 1 of which can be used as a high-speed pulse output (HDO).	
	Analog output terminals	2 outputs as standard: AO1, AO2 (0 ~ 10V or 0/4 ~ 20mA selectable)	
	Relay output	2 relay outputs as standard	
<b>Standard communication interface</b>	RS485 communication	Provide RS485 communication interface to communicate with external RS485, and support Modbus protocol (RTU mode).	
<b>Extended communication interface</b>	PROFIBUS-DP, Ethernet, CAN open	Supports PROFIBUS-DP, CAN open, and Ethernet communication.	
<b>Fault protection</b>	Acceleration overcurrent, deceleration overcurrent, constant speed overcurrent, acceleration overvoltage, deceleration overvoltage, constant speed overvoltage, Bus undervoltage fault, motor overload, VFD overload, input phase loss, output phase loss, rectifier module overheating fault, inverter module overheating fault, external fault, communication fault, current detection fault, motor parameter recognition fault, EEPROM operation fault, PID feedback disconnection, brake unit fault, manufacturer running time reached.		
<b>Special functions</b>	Parameter copy, parameter backup, common DC bus, free switching of two sets of motor parameters, frequency switching, DC braking, short-circuit braking, flux braking, user password usage, over-modulation function, vector control of synchronous motors, speed tracking, oscillating-frequency control, fixed-length control, counting function, pre-excitation, overcurrent stall, overvoltage stall, power-down restart, skip frequency, 4 sets of acceleration/deceleration times, motor over-temperature protection, flexible fan control, process PID control, multi-speed control, instantaneous frequency reduction function, simple PLC control, droop control, parameter identification, weak magnet control, high-precision torque control, V/F separation control, fault recording, etc.		
<b>Keyboard display</b>	LCD	LCD keyboard, optional LED digital keyboard with potentiometer	
<b>Others</b>	Operation place	Indoor, at an altitude of less than 1,000 meters above sea level, free from direct sunlight, and free from dust, corrosive gases, flammable gases, oil mist, water vapor, dripping, salt, etc.	
	Ambient temperature	-10 ~ +40°C, the device should be used with reduced capacity in 40 ~ 50°C. The rated output current should be reduced by 1% for every 1°C of increase.	
	Humidity	5 ~ 95%(no condensation)	
	Altitude	0 ~ 2000 meters, the device should be used with reduced capacity when above 1000 meters. The rated output current should be reduced by 1% for every 100 meters of elevation.	
	Vibration	less than 0.5g	
	Storage temperature	-40 ~ +70°C	

## Product Specification

Model	Power (kW)	Input voltage (V)	Input current (A)	Output current (A)	Power of applicable motor (kW)	Note
RNB2000-2S	0.75	Single-phase 220 VAC	8.2	4.5	0.75	Built-in brake unit as standard
RNB2001-2S	1.5		14.0	7.0	1.5	
RNB2002-2S	2.2		23.0	9.6	2.2	
RNB2000	0.75	Three-phase 380 VAC	8.2	4.5	0.75	
RNB2001	1.5		5.0	3.8	1.5	
RNB2002	2.2		5.8	5.3	2.2	
RNB2004	4.0		12.0	9.5	4.0	
RNB2005	5.5		18.5	14	5.5	
RNB2007	7.5		22.5	18.5	7.5	
RNB2011	11		30.0	25.0	11	
RNB2015	15		39.0	32.0	15	
RNB2018	18.5		45.0	38.0	18.5	
RNB2022	22		54.0	45.0	22	
RNB2030	30		68.0	60.0	30	
RNB2037	37		84.0	75.0	37	
RNB2045	45		98.0	92.0	45	Optional built-in brake unit
RNB2055	55		123.0	115.0	55	
RNB2075	75		157.0	150.0	75	
RNB2090	90		188.0	180.0	90	
RNB2110	110		221.0	215.0	110	
RNB2132	132	267.0	260.0	132		
RNB2160	160	309.0	305.0	160		
RNB2185	185	344.0	340.0	185		
RNB2200	200	384.0	380.0	200		
RNB2220	220	429.0	425.0	220		
RNB2250	250	460.0	480.0	250		
RNB2280	280	500.0	530.0	280		
RNB2315	315	580.0	600.0	315		
RNB2350	350	625.0	650.0	350		
RNB2400	400	715.0	720.0	400		
RNB2450	450	805.0	795.0	450		
RNB2500	500	848.0	860.0	500		

# Product overall dimensions, installation dimensions, and weight

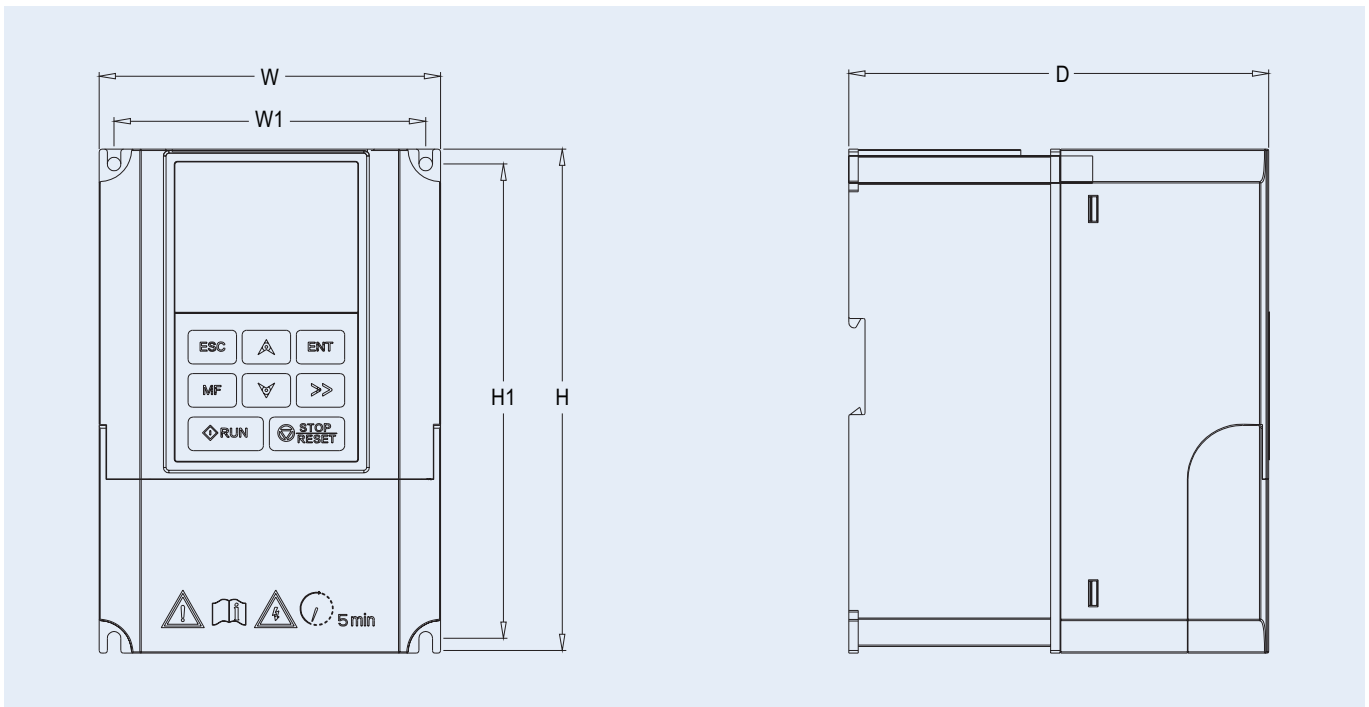
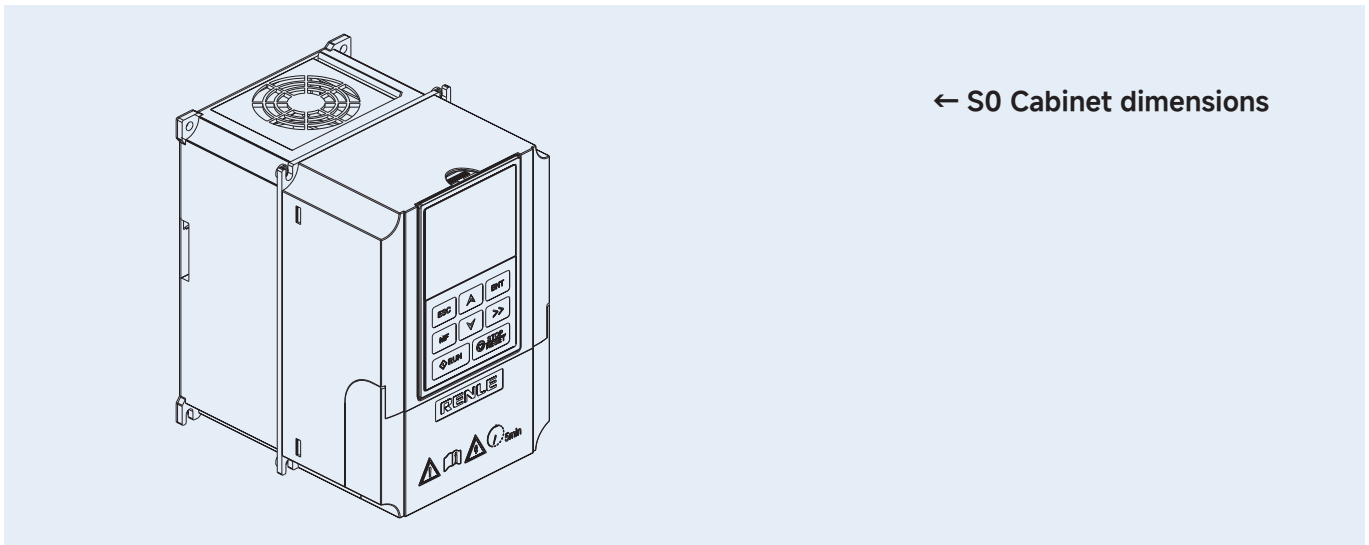

a)Applies to RNB2000 ~ RNB2004

Model	Overall and installation dimensions (mm)						Mounting hole diameter (mm)	Weight (kg)	Cabinet dimensions	Note
	W	H	D	W1	W2	H1				
RNB2000	126	186	155	115	---	175	5	2.0	S0	Wall-mounted
RNB2001										
RNB2002										
RNB2000-2S										
RNB2001-2S										
RNB2002-2S										
RNB2004										

← S1, S2 Cabinet dimensions

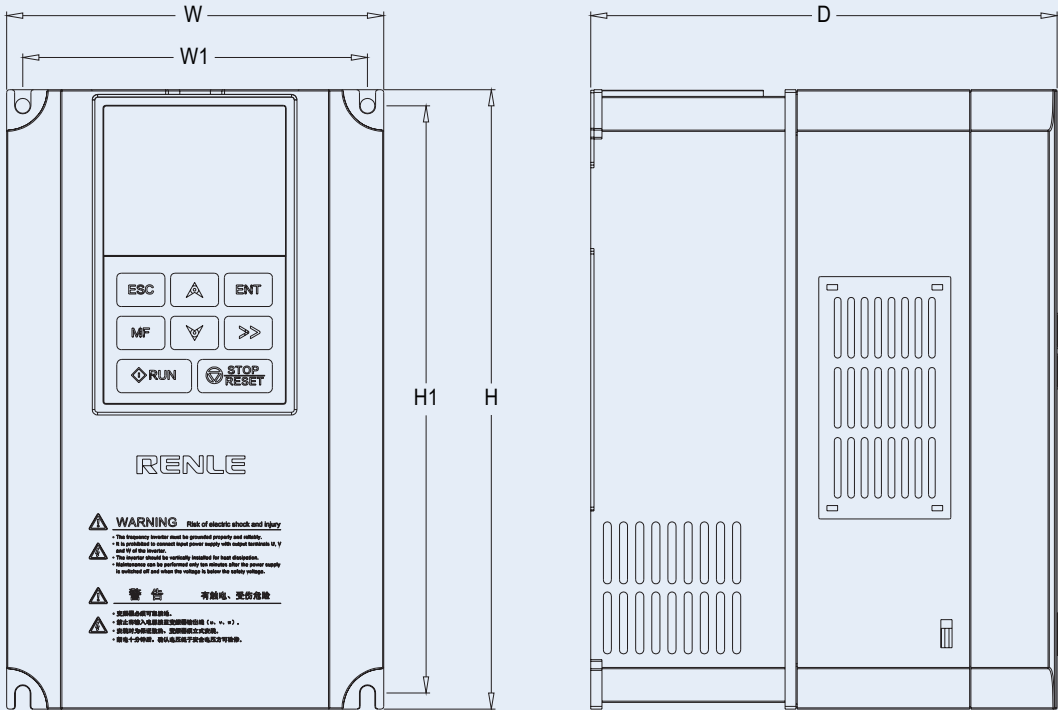
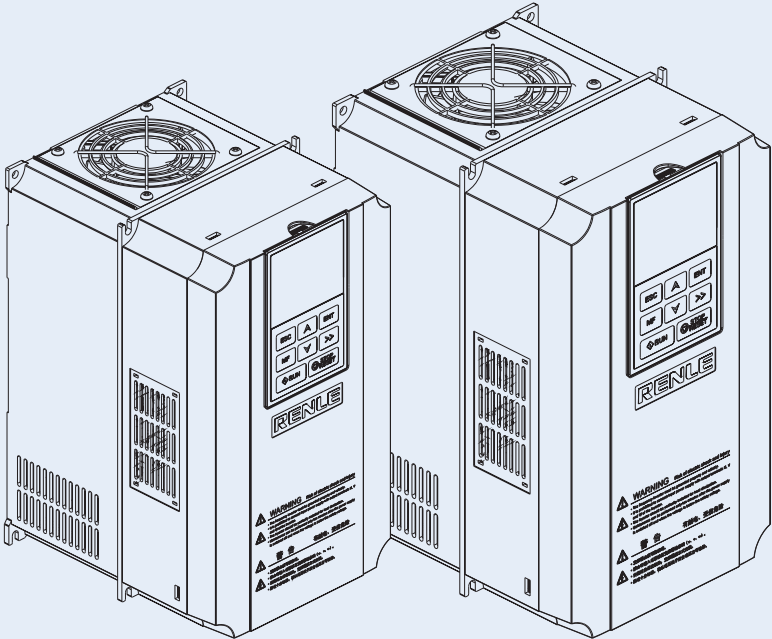

b) Applies to RNB2005 ~ RNB2011

Model	Overall and installation dimensions (mm)						Mounting hole diameter (mm)	Weight (kg)	Cabinet dimensions	Note
	W	H	D	W1	W2	H1				
RNB2005	140	230	172	128	---	218	5.5	3.5	S1	Wall-mounted
RNB2007	165	285	200	153	---	273	5.5	5.4	S2	Wall-mounted
RNB2011										

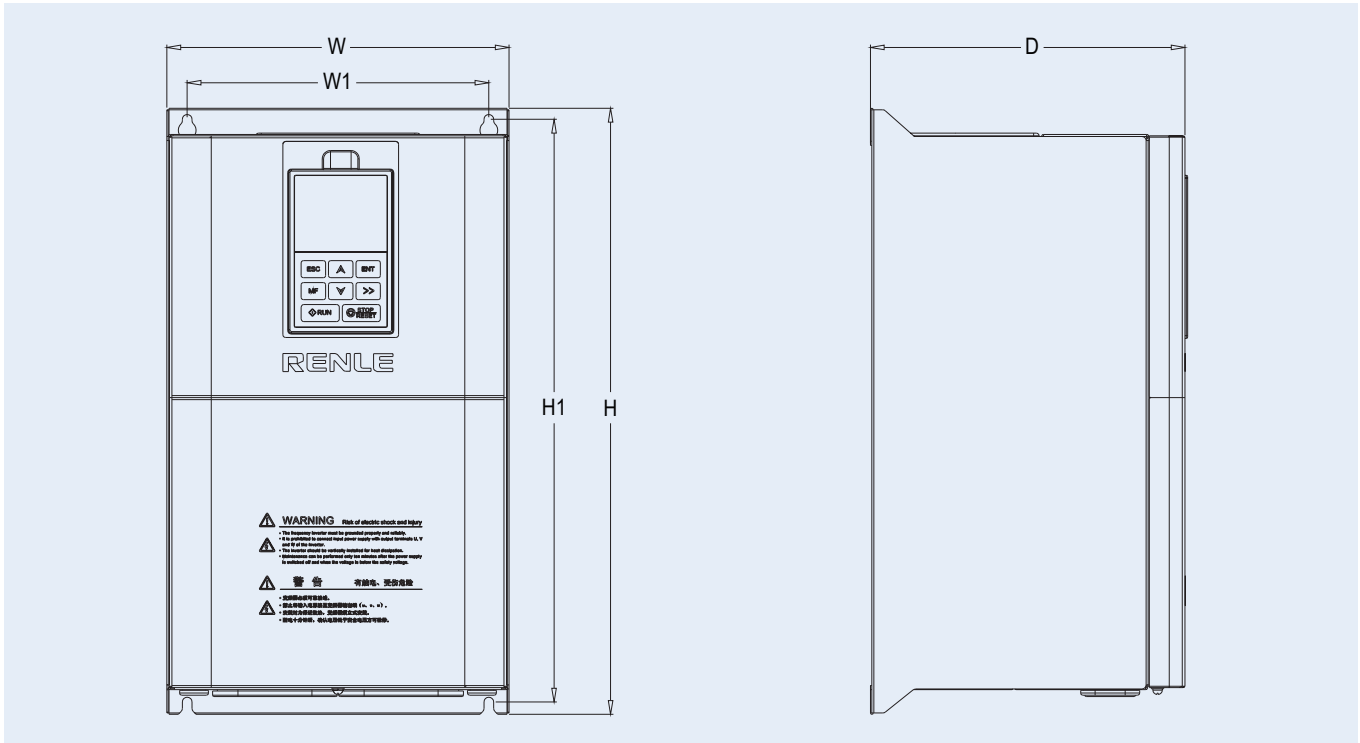
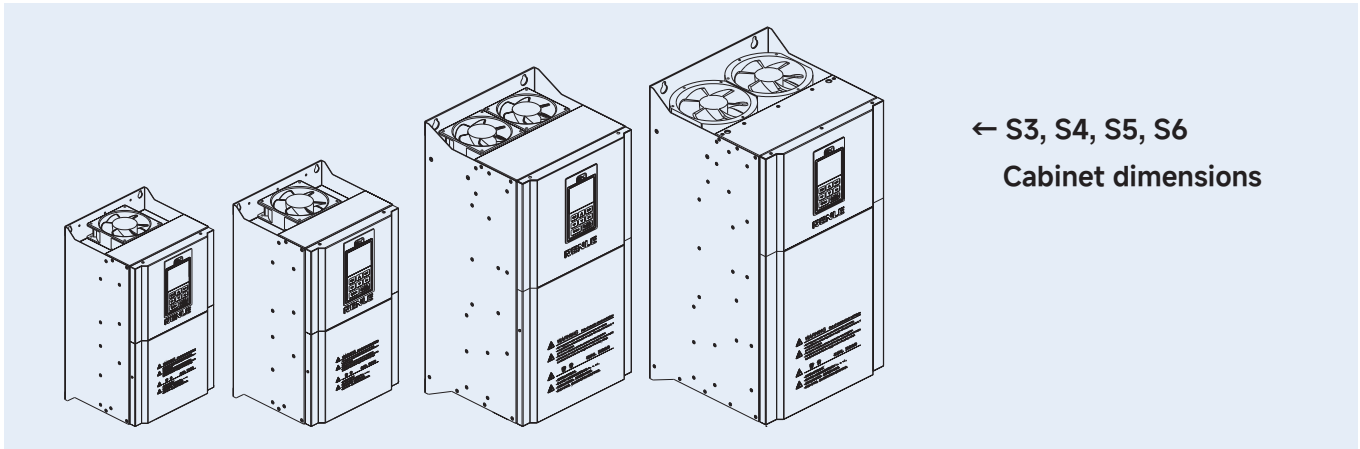

c) Applies to RNB2015 ~ RNB2132

Model	Overall and installation dimensions (mm)						Mounting hole diameter (mm)	Weight (kg)	Cabinet dimensions	Note
	W	H	D	W1	W2	H1				
RNB2015	214	402	205	184	---	385	7	10	S3	Wall-mounted
RNB2018										
RNB2022										
RNB2030	250	442	230	220	---	425	7	15	S4	Wall-mounted
RNB2037										
RNB2045	300	600	280	240	---	580	9	37	S5	Wall-mounted
RNB2055										
RNB2075										
RNB2090										
RNB2110	330	660	332	250	---	640	9	53	S6	Wall-mounted
RNB2132										

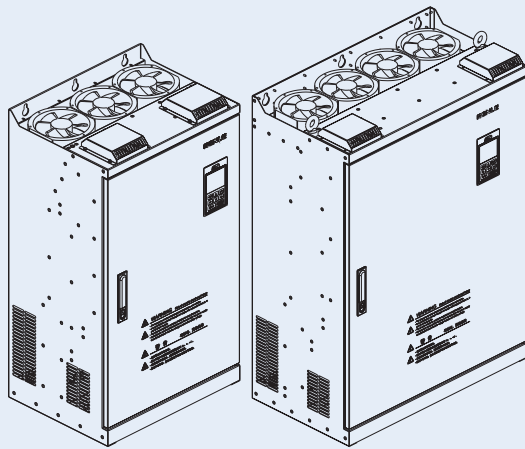

← S7, S8 Cabinet dimensions

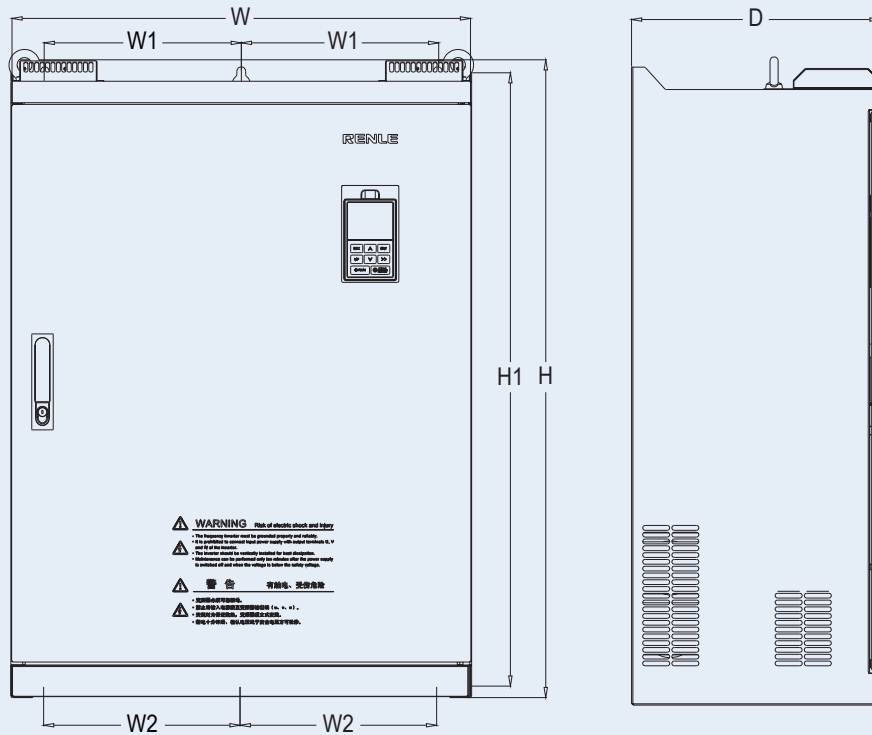

d) Applies to RNB2160 ~ RNB2400

Model	Overall and installation dimensions(mm)						Mounting hole diameter (mm)	Weight (kg)	Cabinet dimensions	Note
	W	H	D	W1	W2	H1				
RNB2160	480	853	354	180	---	826	12	106	S7	Wall-mounted with optional base
RNB2185										
RNB2200										
RNB2220										
RNB2250	680	940	370	290	---	908	14	151	S8	Wall-mounted with optional base
RNB2280										
RNB2315										
RNB2350										
RNB2400										

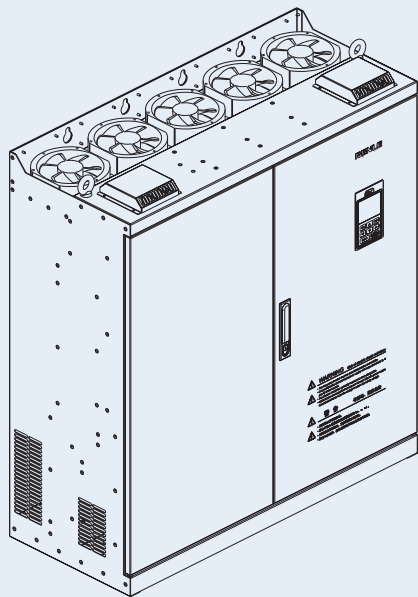

← S11 Cabinet dimensions

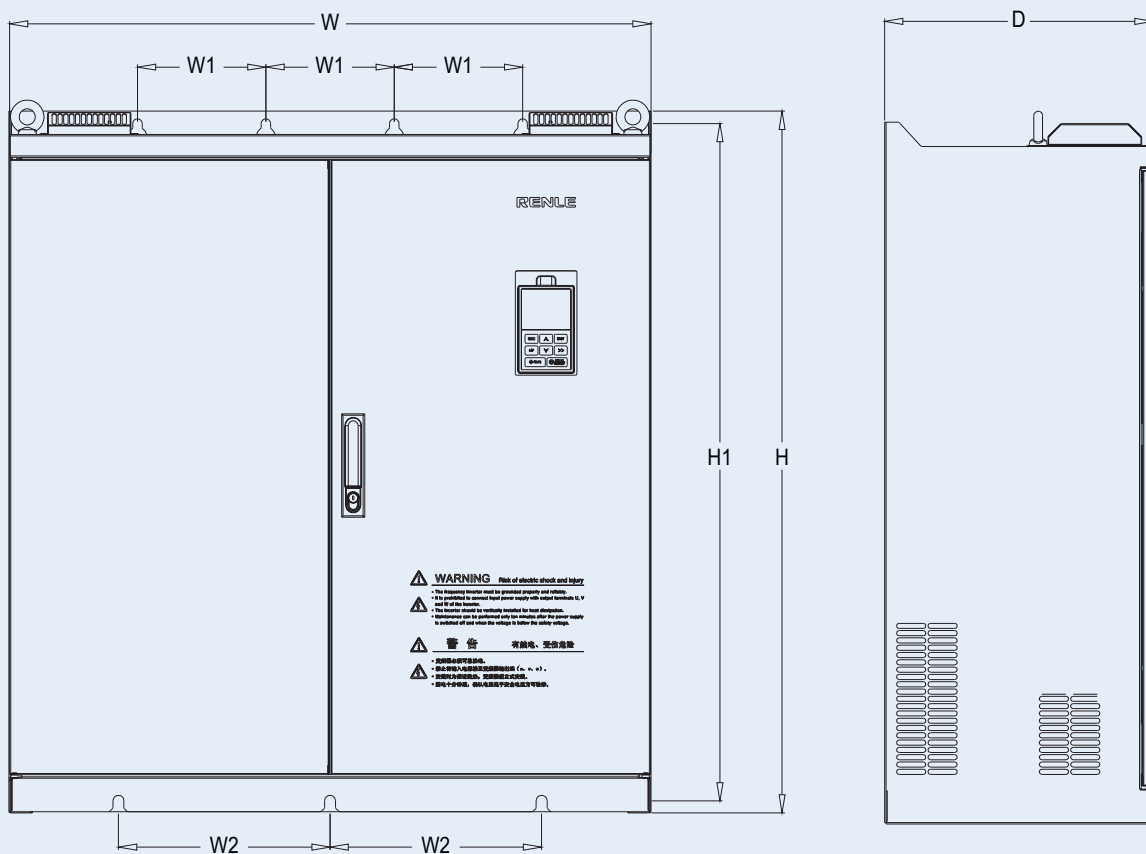

e) Applies to RNB2450 ~ RNB2500

Model	Overall and installation dimensions(mm)						Mounting hole diameter (mm)	Weight (kg)	Cabinet dimensions	Note
	W	H	D	W1	W2	H1				
RNB2450	880	962	370	176	290	928	15	350	S11	Wall-mounted with optional base
RNB2500										

## Operator Panel Dimensions

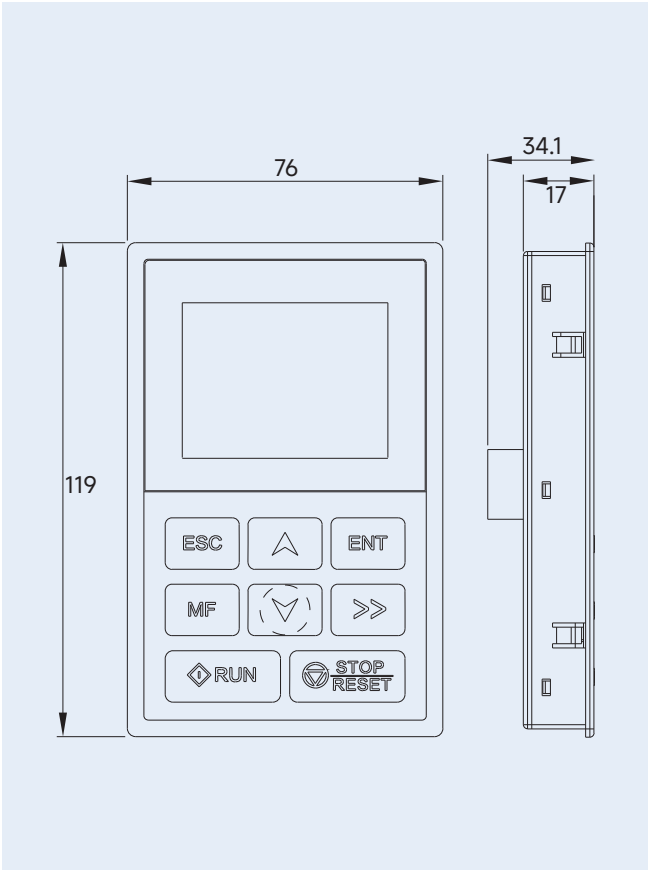

a) Panel dimensions

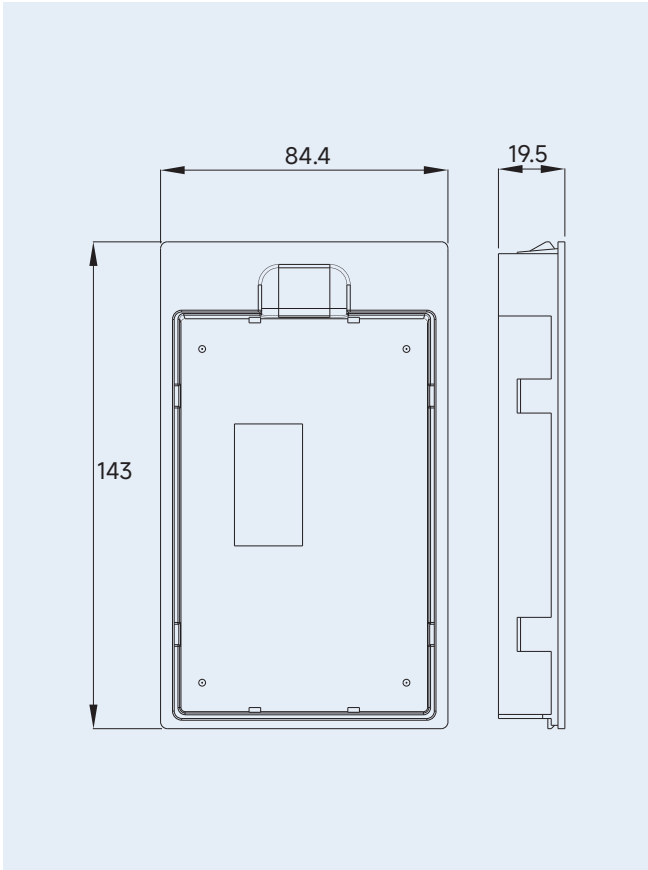

b) Panel bracket dimensions

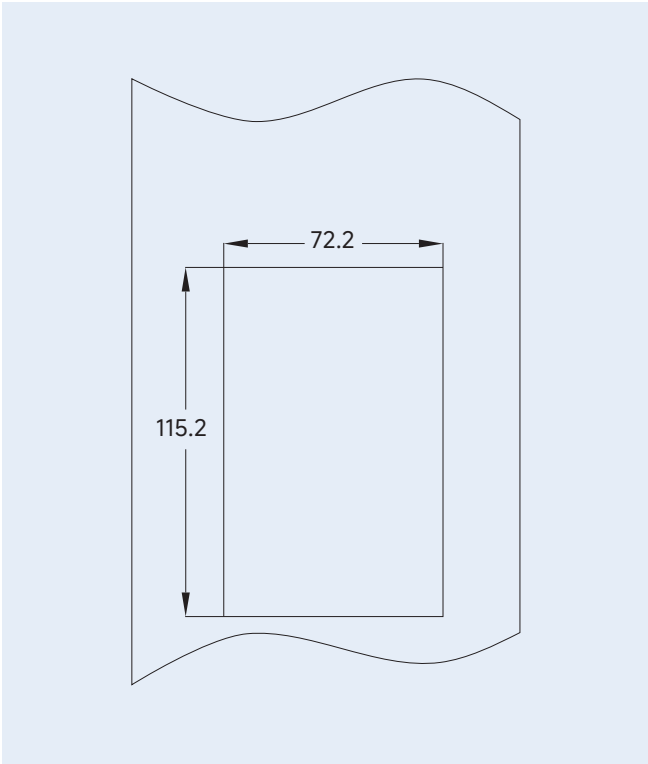

c) Panel cutout dimensions

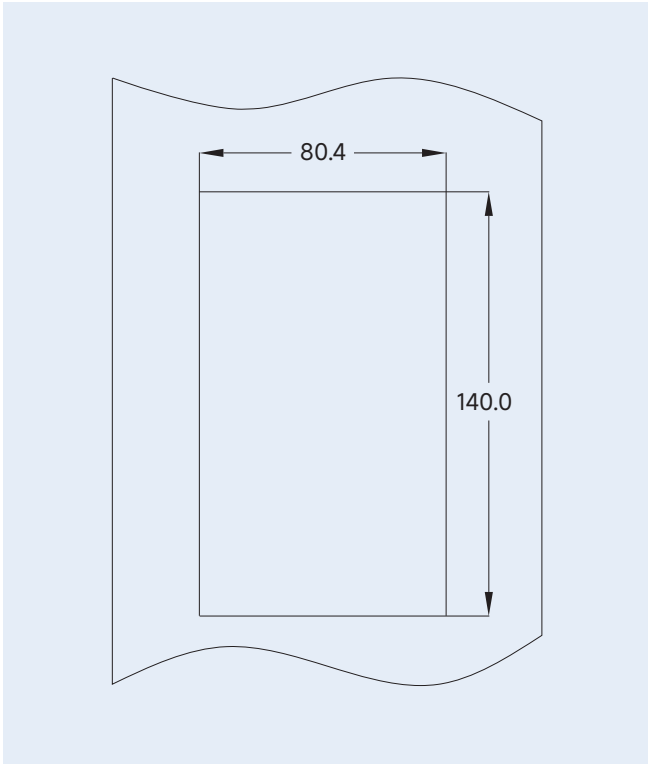

d) Panel bracket cutout dimensions

# Main Circuit Coil Dimensions

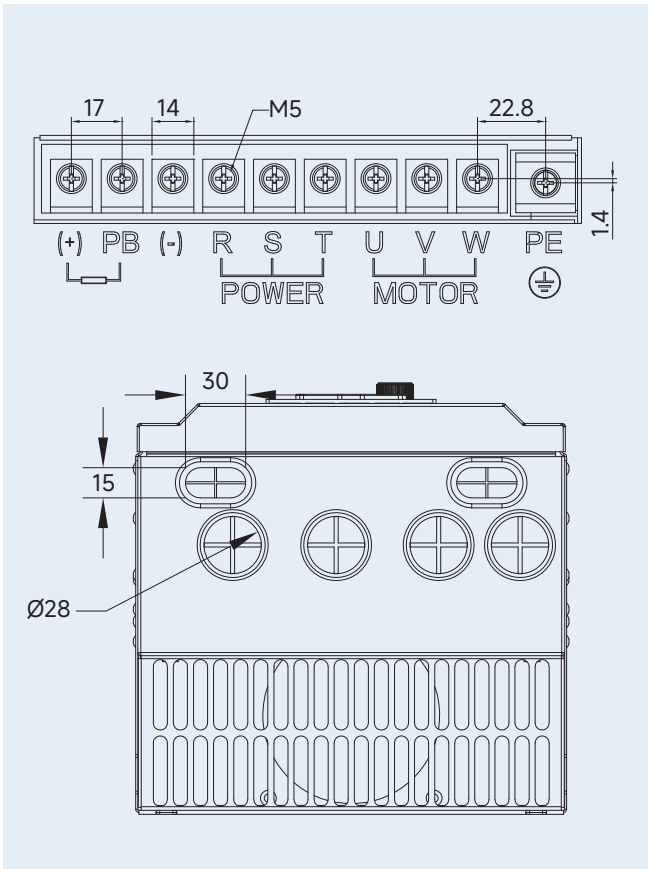

a) Applies to RNB2015 ~ RNB2022

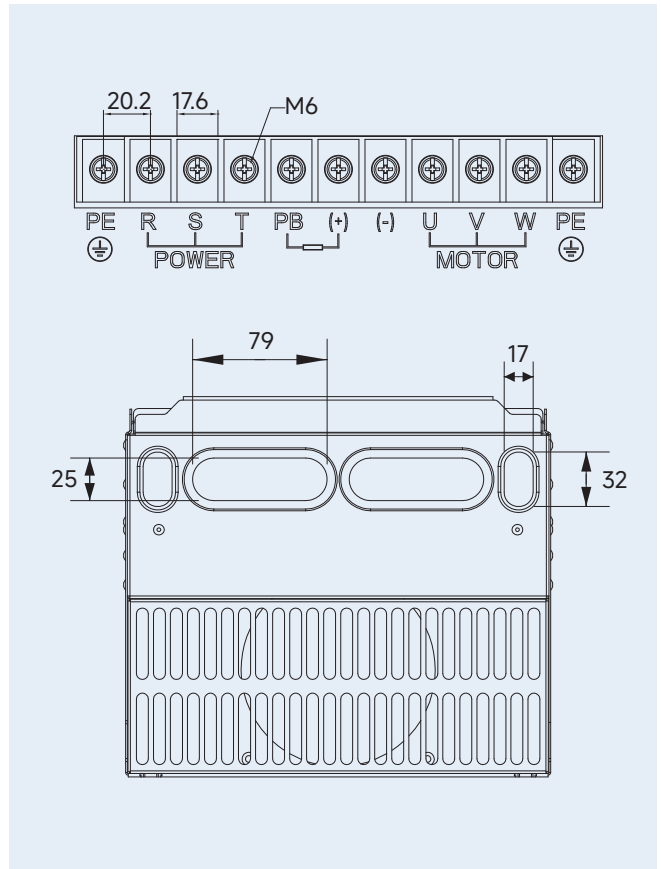

b) Applies to RNB2030 ~ RNB2037

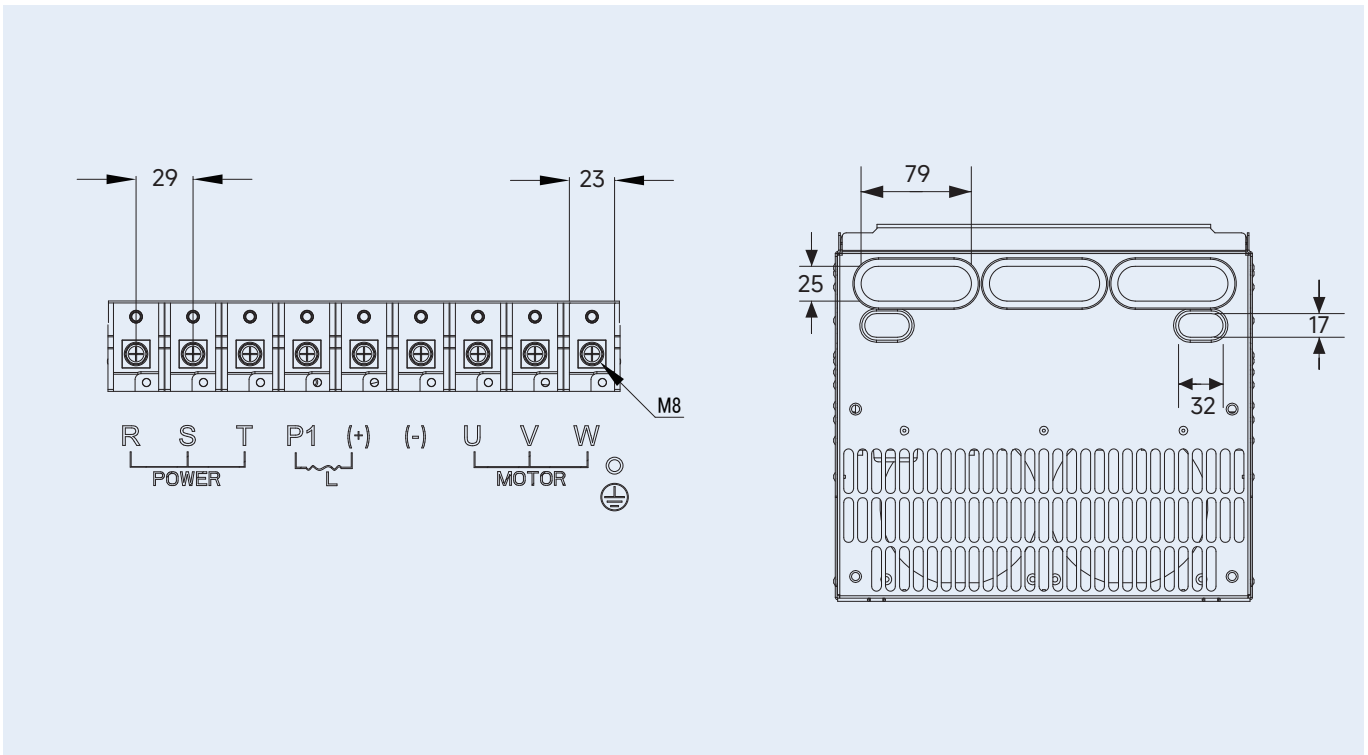

c) Applies to RNB2045 ~ RNB2090

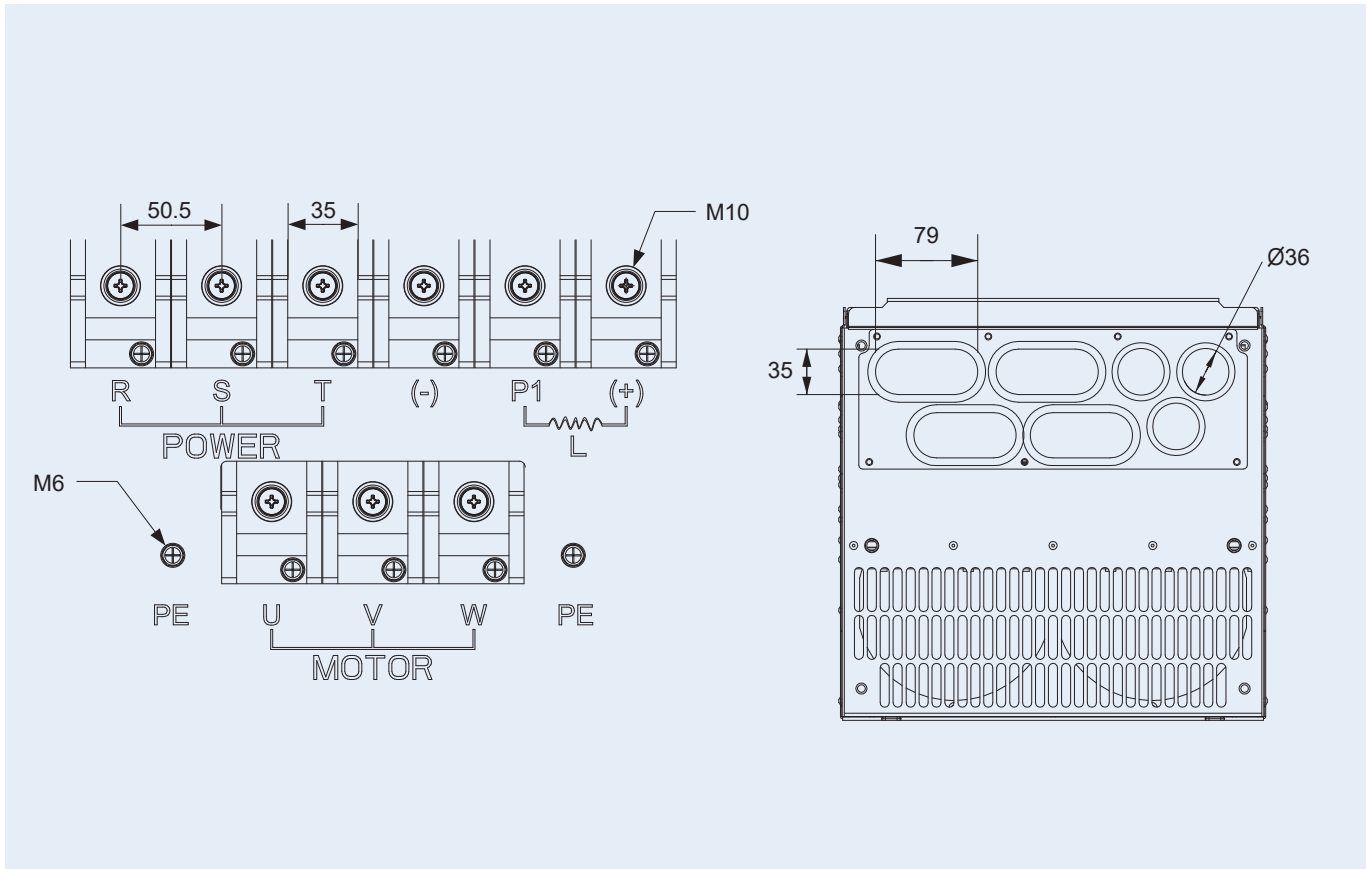

d) Applies to RNB2110 ~ RNB2132

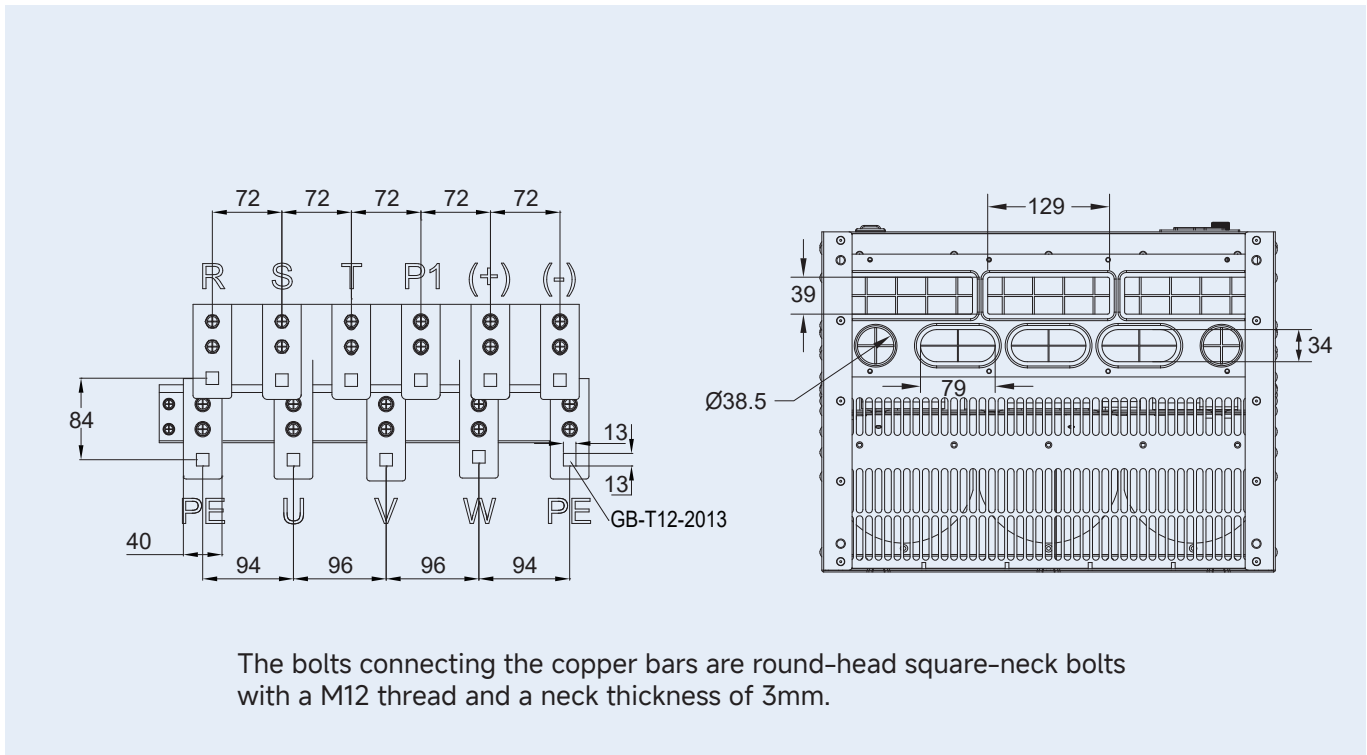

The bolts connecting the copper bars are round-head square-neck bolts with a M12 thread and a neck thickness of 3mm.

e) Applies to RNB2160 ~ RNB2250

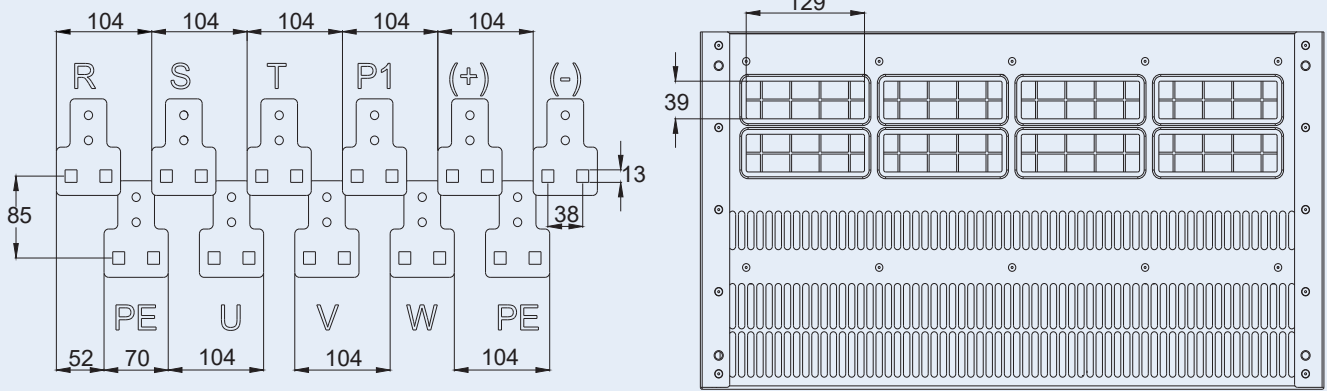

The bolts connecting the copper bars are round-head square-neck bolts with a M12 thread and a neck thickness of 3mm.

**f) Applies to RNB2280 ~ RNB2400**

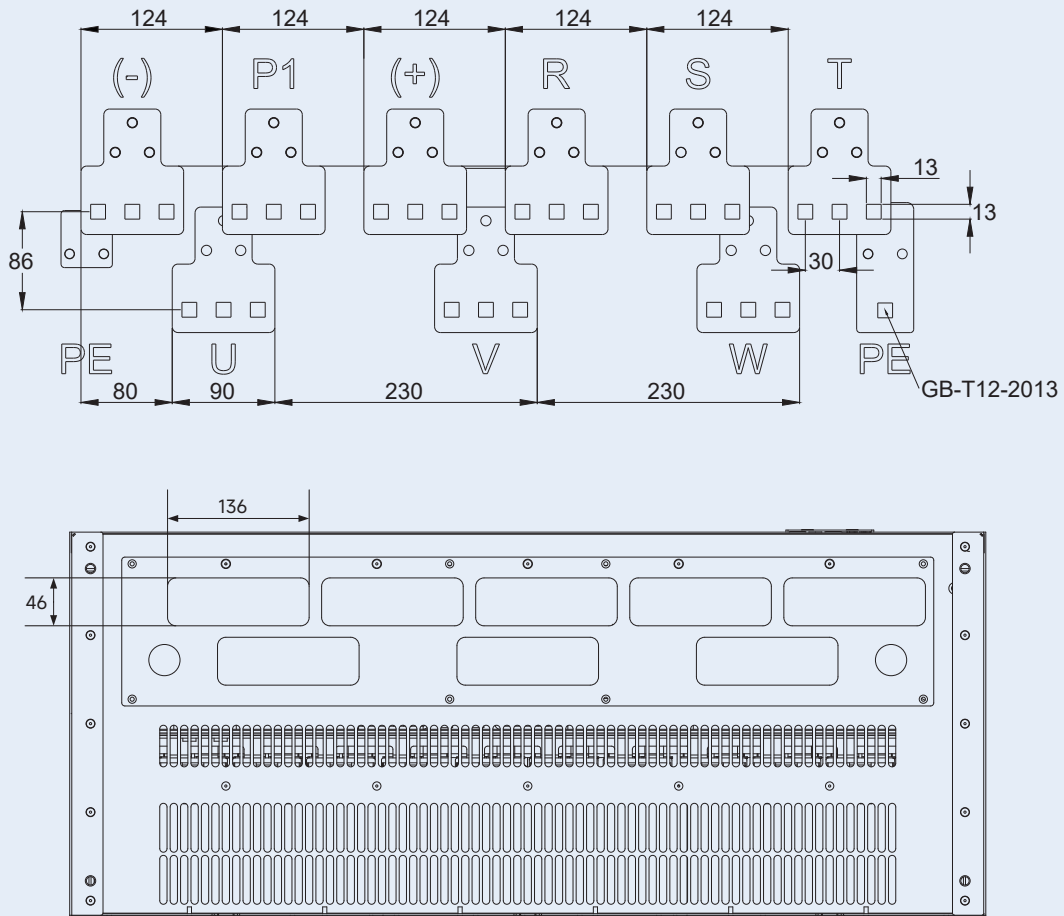

The bolts connecting the copper bars are round-head square-neck bolts with a M12 thread and a neck thickness of 3mm.

**g) Applies to RNB2450 ~ RNB2500**

## Standard Wiring Diagram

Please refer to the following diagram for the wiring of the VFD. When it is operated from the keypad panel, it can start the motor by merely wiring the main circuit.

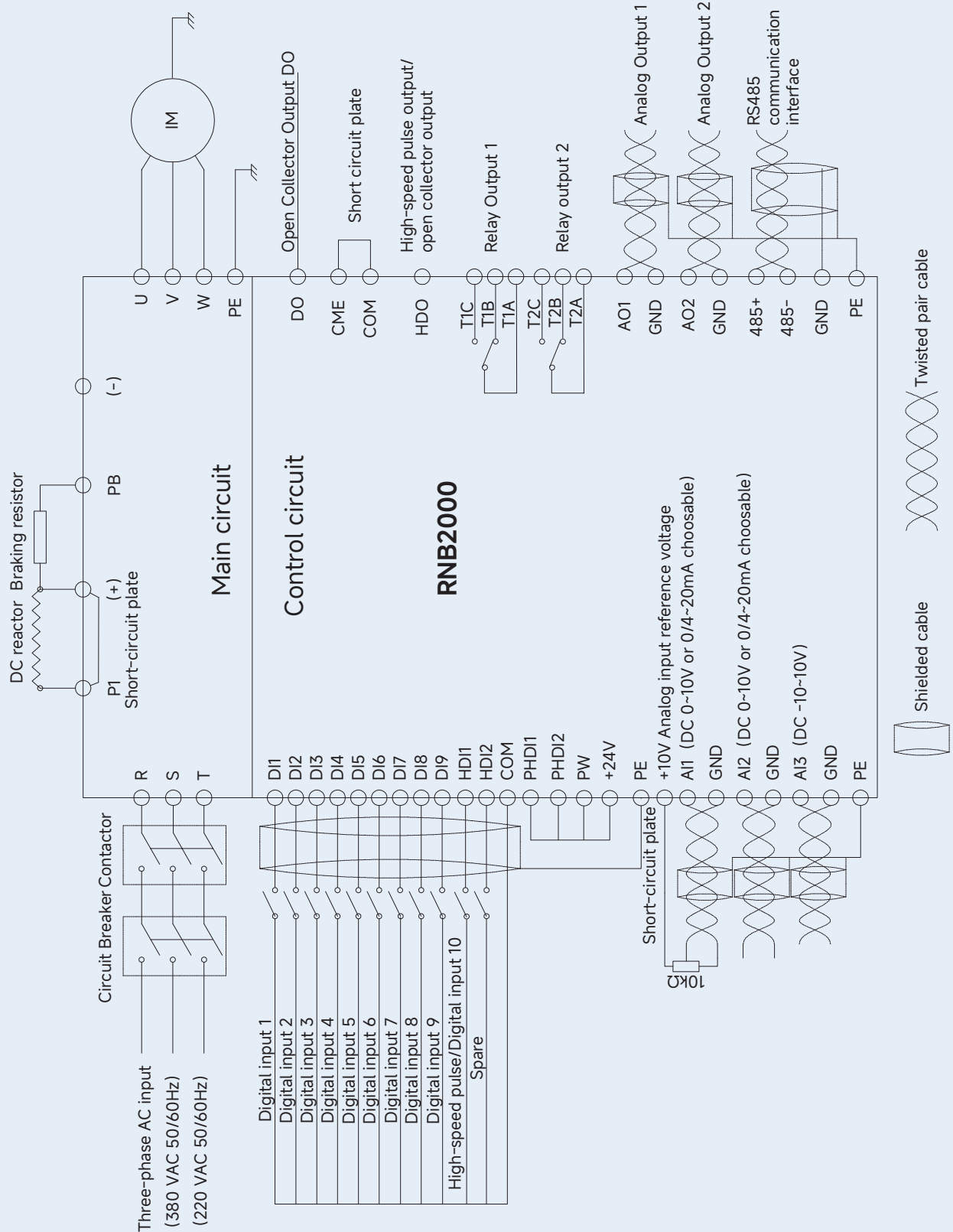

# Control Circuit Terminal Description

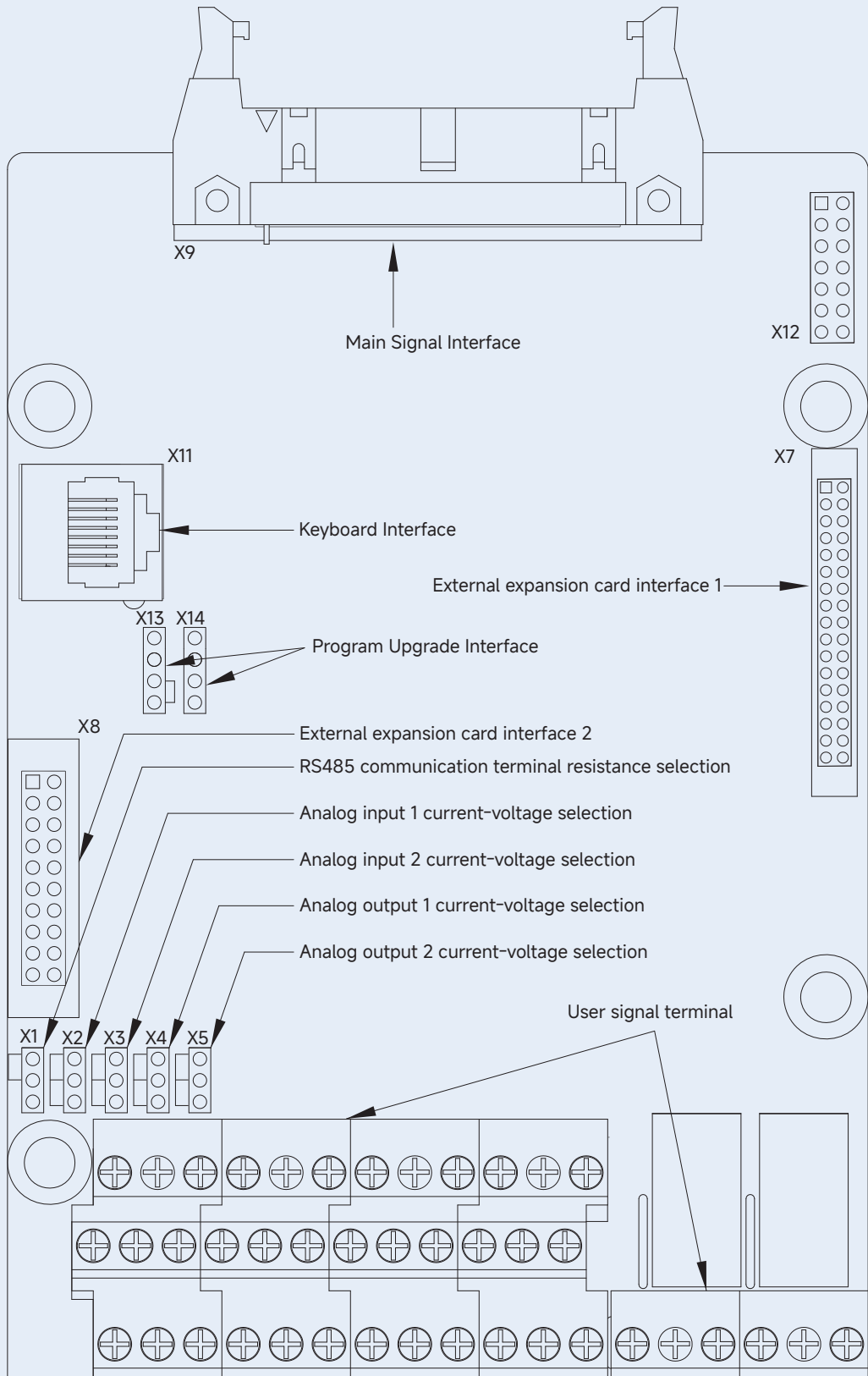

## Function table of control panel terminals

Type	Terminal Symbol	Terminal Function Description	Technical Specification
Digital Input	+24V	+24V power supply	24V±10%, internally isolated from GND. Maximum load 200mA
	PW	External power input terminal (digital input terminal power supply)	Factory setting: short circuit with +24V
	DI1~DI9	Digital input terminals 1~ 9	Input specification: 24V, 5mA
	HDI1, HDI2	High-speed pulse input or Digital input, HDI2 bit spare terminal	Pulse input frequency range: 0~ 50kHz High level voltage: 24V
	PHDI1,PHDI2	HDI1/HDI2 external power supply input terminal	Factory setting: short circuit with +24V
	COM	+24V power supply or external power supply	Internally isolated from GND
Digital Output	DO	Open collector output with CME common terminal	External voltage range: 0 ~ 24V
	CME	Open collector output common terminal	Factory setting: short circuit with COM
	HDO	High-speed pulse output or open collector output with CME common terminal	Pulse output frequency range: 0 ~ 50kHz
	COM	HDO common terminal	Internally isolated from GND
Analog Input	+10V	+10V power output provided by the VFD	Output current range: 0~50mA (if a potentiometer is connected between +10V and GND, its resistance value should be not less than 2kΩ)
	AI1	Analog input terminal 1	Input voltage and current choosable Input voltage range: 0V ~ 10V Input current range: 0/4 ~ 20mA
	AI2	Analog input terminal 2	Input voltage and current choosable Input voltage range: 0~10V Input current range: 0/4~20mA
	AI3	Analog input terminal 3	Input voltage range: -10V~10V
	GND	Analog ground	Internal isolation from COM
Analog Output	AO1~AO2	Analog output terminal	Output voltage and current choosable Output voltage range: 0~10V Output current range: 0/4~20mA
	GND	Analog ground	Internal isolation from COM
Relay output	T1A/T1B/T1C	Relay output	T1A-T1B: Normally closed T1A-T1C: Normally open Contact capacity: 250 VAC/3A, 30 VDC/1A
	T2A/T2B/T2C	Relay output	T2A-T2B: Normally closed T2A-T2C: Normally open Contact capacity: 250 VAC/3A, 30 VDC/1A
Communication Interface	485+/485-	RS485 communication interface	RS485 communication interface
Ground Terminal	PE	Ground terminal	Ground terminal

## Instructions for the use of product peripheral components

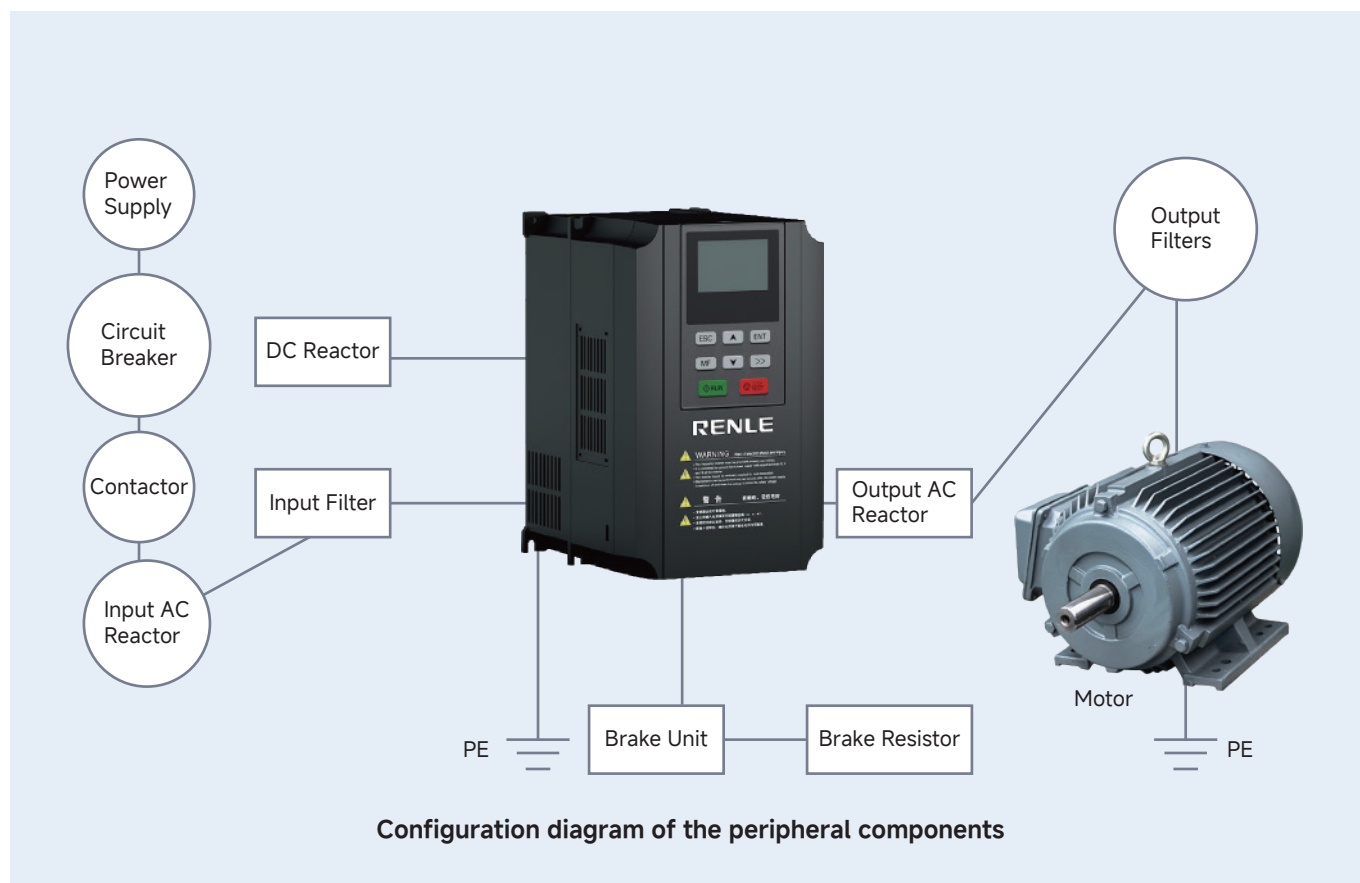

## Function table of the peripheral components

Name	Function Description
<b>Circuit Breaker</b>	Application: To cut off the power supply and protect the back-end equipment in case of failure of the back-end equipment.
	Selection: The breaking current of the circuit breaker should be 2 times the VFD current.
<b>Contactor</b>	Do not switch the contactor on and off frequently, as this will cause the VFD to malfunction; do not start and stop the VFD through the on-off of the main circuit, as this will affect its service life.
<b>Input Reactor DC Reactor</b>	To improve power factor;
	To improve the effect of input power supply unbalance on the system;
	To suppress high harmonics and reduce the transmission of harmonics to the outside;
	To effectively suppress the effect of pulse current on the rectifier bridge.
<b>Input Filter Output Filter</b>	To reduce the interference of VFD to peripheral equipments.
<b>Brake Unit Brake Resistor</b>	To consume the energy feedback from the motor during braking for fast braking.
<b>Output Reactor</b>	To reduce VFD protection due to leakage current;
	It is recommended to install when the connection between the VFD and motor exceeds 100 meters.

## Examples of product applications

### Application in the hoisting industry



## Feature

- **High starting torque and fast response**

Vector control without PG, 0.25Hz, up to 180% output torque, <10ms torque response time;  
Vector control with PG, 0Hz, up to 200% output torque, <5ms torque response time;  
It can prevent accidents such as load slip due to insufficient torque at a low speed.

- **Support dual motor switching**

The VFD can set two sets of motor parameters separately to cope with the situation where 1 VFD is required to drive 2 different motors for linear motion and translational movement.

- **Brake control function**

The brake logic control and monitoring function of the VFD is designed for the hoisting industry, which is more flexible to realize the smooth starting and stopping of the crane and effectively prevent the objects from dropping.

- **Perfect protection function**

With a full range of alarm and protection functions, the VFD meets the requirements of industry safety standards.

## Application

Tower cranes, bridge cranes, harbor cranes, electric hoists, construction hoists, winch gates, electric winches, and mine hoists.



## Application in the oilfield industry



### Feature

- Low frequency and high torque;
- No shock to the power grid during operation;
- Without belt and pulley. The asynchronous motor on the oil well is replaced by semi-direct drive synchronous motor for safety.
- Semi-direct drive synchronous motors are more efficient than asynchronous motors;
- It is more energy-saving to feedback energy generated when the oil well pumping machine is downstream to the power grid with built-in energy feedback unit;
- The stroke can be adjusted by knob without the need to replace the belt and gear.

### Application

Beam-pumping unit and tower pumping unit.



## High-speed permanent magnet synchronous motor-specific VFD



In the context of carbon neutrality, Shanghai RENLE has developed a special drive for high-speed permanent magnet synchronous motors on the basis of RNB2000 series variable frequency drive. RNB2000FH series high-speed permanent magnet synchronous motor-specific VFD is widely used in magnetic levitation, air levitation motor and other high-speed high-end applications. For example, when applied to fully automatic knife wheel cutting equipment, it drives the air suspension high-speed spindle, which can be used for cutting silicon, ceramics, glass, gallium arsenide, indium phosphide and other materials, various types of lead frame/substrate packages, 6-12 inch wafers and other materials. When driving air suspension or magnetic suspension high-speed compressors, high-speed blowers, and high-speed vacuum pumps, it can be used in wastewater treatment, papermaking, metallurgy, textile, cement, chemical, fine processing and other industries.

### Feature

- High efficiency, high speed and low noise, suitable for high-speed air levitation and magnetic levitation motors;
- 16KHz carrier frequency with no motor vibration and low noise;
- Maximum speed up to 72000Rpm, motor efficiency over 98%;
- With the energy-saving vector control algorithm, it can save energy up to 20% - 50%.

### Application

High-speed air/magnetic levitation fan, high-speed air/magnetic levitation compressor.

## Partial performance in the power industry



Electric power industry

Shanxi Lu'an Ronghai Power Generation Co., Ltd	Shandong Zhucheng Longguang Thermal Power Co., Ltd
Shandong Zaozhuang Jiayang Thermal Power Co., Ltd	Shandong Weihai Thermal Power Group Co., Ltd
Huadian International Power Co., Ltd. Anhui Huadian Lu'an Power Plant Co., Ltd	
China Power International Development Co., Ltd. Shanxi Shentou Power Generation Co., Ltd	
Inner Mongolia Datang International Renewable Resources Development Co., Ltd	
China Datang Group Co., Ltd. Datang Gansu Power Generation Co., Ltd	
China Datang Group Co., Ltd. Datang Lubei Power Generation Co., Ltd	
China Huadian Group Co., Ltd. Hubei Xiangyang Huadian Power Generation Co., Ltd	
China Huadian Group Co., Ltd. Guizhou Huadian Tangzhai Power Generation Co., Ltd	
China Huadian Group Co., Ltd. Shaanxi Huadian Yuheng Coal Power Co., Ltd .....	

## Partial performance in the steel industry



Steel industry

China Baowu Iron and Steel Group Co., Ltd	Ma'anshan Iron and Steel Co., Ltd
Houying Group Haicheng Steel Co., Ltd	Xining Special Steel Co., Ltd
Hebei Xingang Iron and Steel Group Co., Ltd	Fujian Sangang (Group) Co., Ltd
Pangang Group Co., Ltd. Xichang Steel Vanadium Co., Ltd	Tonghua Steel Co., Ltd
Jiangsu shagang Group Co Ltd	Hebei Zongheng Iron and Steel Group Co., Ltd
Benxi Iron and Steel (Group) Co., Ltd	Anyang Iron and Steel Co., Ltd
Hyundai Steel Company of Hyundai Group in Korea	Zhongtian Steel Group Co., Ltd
Xuanhua Iron and Steel Group Co., Ltd	Rizhao Steel Rolling Co., Ltd
Shandong Iron and Steel Group Laiwu Iron and Steel Xinjiang Co., Ltd	
Shaanxi Iron and Steel Group Shaanxi Longmen Iron and Steel Co., Ltd ...	

## Partial performance in the paper industry



Paper industry

Shandong Sun Paper Industry Co., Ltd	Vietnam Shun'an Paper Industry Co., Ltd
Dongguan Junye Paper Industry Co., Ltd	Shandong Tianhe Paper Industry Co., Ltd
Shandong Huatai Paper Industry Co., Ltd	Shanxi Qiangwei Paper Industry Co., Ltd
Shandong Huamai Paper Industry Co., Ltd	Puyang Longfeng Paper Industry Co., Ltd
Fuyu Chenming Paper Industry Co., Ltd	Henan Xinmi Hengfeng Paper Industry Co., Ltd
Shandong Tianzhang Paper Industry Co., Ltd	Shandong Ronghua Paper Industry Co., Ltd
Jiulong Global (China) Investment Group	Shanying International Holdings Co., Ltd
Shandong Hengyu Paper Industry Co., Ltd	Shandong Jianghe Paper Industry Co., Ltd
Jiangsu Yangzi Shengda Paper Industry Technology Development Co., Ltd	
Zhejiang Rongsheng Environmental Protection Paper Industry Co., Ltd ...	

## Partial performance in the coal industry



### Coal industry

Jiangxi Fengcheng Qujiang Coal Development Co., Ltd	Zaozhuang Mining (Group) Co., Ltd
Kailuan (Group) Weizhou Mining Co., Ltd	Guangxi Bainaihe Mining Co., Ltd
Guizhou Panxian Zisenyuan Group Company	Huating Coal Industry Group Co., Ltd
Shenhua Ningxia Coal Industry Group Co., Ltd	Shanxi Lanhua Coking Coal Baoxin Coal Industry Co., Ltd
Xinjiang Tunnan Coal Industry Co., Ltd	China Pingmei Shenma Group Thirteenth Mine
Shanxi Coke Group Co., Ltd	Zuoquan Xinshun Coal Industry Co., Ltd. of Shanmei Group
Shanxi Xiyang Fenghui Coal Industry Co., Ltd	Inner Mongolia Shendong Coal Company
Shandong Yankuang Group Co., Ltd	Xinjiang Xinsai Shuanglu Mining Co., Ltd
Yutian County Guyu Coal Coking Co., Ltd	Qinghai Jiangcang Coal Industry Co., Ltd
Shanxi Coal Import and Export Group Zuoyun East Gucheng Coal Industry Co., Ltd ...	

## Partial performance in the water conservancy industry



### Water conservancy industry

Shanghai Nanhui Collection Rainwater Pump Station	Jinghui Large Pump Station in Baiyin City, Gansu Province
Tianjin Binhai New Area Central Bridge Yinhe Pump Station	Inner Mongolia Wulante Qianqi Water Supply Project
Jingdian Large Pump Station of Jingtaichuan Electric Power Irrigation Management Bureau in Gansu Province	
Reclaimed Water Reuse Project of Housing and Urban Rural Development Bureau in Siping City, Jilin Province	
Yijingtan Large Pump Station in Alashan League, Inner Mongolia Autonomous Region	
Connection of the Chengdong Water System in Jingmen City, Hubei Province to the Sutai Lake Pumping Station	
Ecological Migration Poverty Alleviation and Development Water Supply Project in Central Gansu Province	
Continued Construction and Distribution Project of Zaozhuang City on the East Line of the South to North Water Diversion Project	
Hebei Urban and Rural Water Supply Source Project in Zhongning County, Ningxia Province	
Gansu Province Taoyin Water Supply Phase II Qin'an County Urban and Rural Water Supply Good Ground Beam Project ...	

## Partial performance in the petrochemical industry



### Petroleum industry

Sinopec Shengli Oilfield Co., Ltd	Shandong Haixin Petrochemical Co., Ltd
CNOOC Tianjin Liquefied Natural Gas Co., Ltd	China Petroleum Sichuan Petrochemical Co., Ltd
CNOOC Huizhou Petrochemical Co., Ltd	Shandong Huafeng Petroleum Technology Co., Ltd
China National Petroleum Corporation Daqing Oilfield Co., Ltd	Wusu Huatai Petrochemical Co., Ltd
Jiangnan Petroleum Drill Bit Co., Ltd	Shandong Haixin Petrochemical Co., Ltd
PetroChina Karamay Oilfield Branch	China Petroleum Dagang Oilfield Company
Xinjiang Zhongji Petrochemical Co., Ltd	Qingdao China Petroleum Warehousing Co., Ltd
China National Petroleum Corporation Liaohe Oilfield Branch	CNOOC Guangxi Fangchenggang Natural Gas Co., Ltd
China Petroleum and Chemical Corporation Natural Gas Sichuan East Pipeline Branch	
Hainan Fushan Oilfield Exploration and Development Co., Ltd. of China National Petroleum Corporation ...	

# RENLE

**上海雷诺尔科技股份有限公司**  
Shanghai RENLE Science&Technology Co., Ltd.

Address: No.188 Building 1, Lane 3968, Chengbei Road,

Jiading District, Shanghai, China

Zip code: 201807

Tel: 021-5996 6666

Fax: 021-5916 0987

Http:// [www.renle.com](http://www.renle.com)

E-mail: [renle@renle.com](mailto:renle@renle.com)

National toll free service hotline: 800-8200-785

2024.12



For more technical and product information,  
please follow the WeChat Public Service Account of RENLE.

The products and technical descriptions introduced in this material are subject to technical updates and material revision without notice. For the latest information, please visit RENLE's official website: [www.renle.com](http://www.renle.com). The final interpretation right of this material belongs to Shanghai RENLE Science & Technology Co., Ltd.

